



## Networked Monitoring System

### DESCRIPTION

KnowzNet™ is a control panel-based fixed monitoring system supporting up to 8 remote sensor heads.

Sensor heads are available for a variety of toxic and combustible gases as well as for security and environmental monitoring applications.

Sensor heads can be installed up to 300 feet (100m) away from the panel.



### Real-time monitoring and control

Sensors are polled continuously for alarms, error or failure.

Sensor response/recovery times are less than 10 seconds.

Panel generates audio/visual alerts upon sensor alarm.

Peak register for each sensor.

Alarm time/date/level stored to non-volatile memory for later recall.

Two sets of dry relay contacts provided to switch external loads upon alarm, such as sirens, gas shut-off valves, ventilation fans, etc.

Optional: 8 zone-specific relay contacts for process control, wiring into security systems, etc.

Remote monitoring/control via modem or PC using serial or USB interface.

### Intelligent. Simple to maintain and service

Durable anodized aluminum panel/sensor head enclosures

Made in Canada quality. One year parts and labor warranty

Digital sensor zeroing/calibration via panel interface or PC: Zero sensors in clean air with button press/mouse click, Span sensors with span gas by correcting reading with button press/mouse-click.

Automatic sensor baseline monitoring to manage drift.

5 years+ typical sensor life time. Replacement sensors available to you within 48 hours.

Panel firmware is field-upgradeable. Firmware upgrades are available for download from Neodym web site.

Technical support response within 24 hours via telephone/email.



Hang or recess mount



Hook-up with telephone cable



Connection is a "snap"

### Easy to install and hook-up

The control panel can be hang-mounted or recess-mounted.

Sensors are factory pre-calibrated.

Sensor heads snap-connect into RJ-11 (telephony) plugs using regular telephone cords/cables.

Easy assimilation into Category 2 (or better) structured wiring systems.



4 sensor ports on two sides



Sensor sockets for field replacement

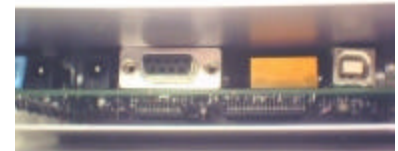

Serial / USB ports and DC jacks

### Simplified operator interface

Each zone/sensor has associated dual-color light-emitting diode:

- Steady Green: Okay
- Steady Red: Alarm
- Green Blink: User accessing menu
- Red blink: sensor error/failure

Simple English menu system accessible via 2-line LCD display and Up/Down/Select/Clear buttons.

Simple or extended functionality operating modes.



Sensor heads are small and unobtrusive

### Powering flexibility

Standard panels operate at 12 Volts DC which facilitates international and vehicular installation.

Special panels are available with a 12 to 40 VDC primary input voltage range.

110VAC adapter is included. Spare power jack is available for optional battery back-up.

Power to the sensor heads is supplied centrally from the control panel via the cables.

### Advanced functions with PC software

Hook-up to PC serial or USB port. CD included for Windows 98/Me/XP/NT/2000

Access panel status and functions using rich PC user interface (color display, mouse, etc.)

Perform data logging and charting

Dial-out via PC modem to pager or central monitoring system or dial-in to monitor/control.

Upload status/data to web server for Internet monitoring via PC TCP/IP client

### Affordably priced

Standard panel (one relay) for \$685.

Combustible sensor heads \$66.40 each.

Refrigerant sensor heads \$98 each.

8-sensor system combustible system for \$1,216.20

8-sensor freon system for \$1,469

*Note: Prices in U.S. dollars FOB Vancouver. Prices subject to change without notice.*

## Specifications

Note: These specifications relate to the KnowzNet™ control panel only.

For specific sensing parameters such as sensing range, accuracy, resolution, operating conditions, etc., please refer the specific product data sheet for the sensor head of interest.

### DATA ACQUISITION

PARAMETER	SPECIFICATION	NOTES
Sampling rate	1,000 samples/second	Ports polled round robin
Resolution	8 bits	
Accuracy	½LSB	(0.2%)
Response Time	1 Second Typ. 5 Seconds Max.	
Start-up Time	30 Seconds	

### ENVIRONMENTAL

PARAMETER	SPECIFICATION	NOTES
Storage Temperature	-40 °C to +85 °C	
Operating Temperature	0 °C to +70 °C	
Relative Humidity	10% to 95%	
Altitude/Pressure	Atmospheric +/- 10%	

### PHYSICAL

PARAMETER	SPECIFICATION	NOTES
Dimensions	216 x 147 x 25 mm	See referenced mechanical drawings
Weight	250g	

### INPUT / OUTPUT DEVICES

PARAMETER	SPECIFICATION	NOTES
Port indicator lamps	Bi-color LED (8)	Red/Green
Text display	2 line x 8 LCD	31 x 14 mm viewing area
Operator keypad	Up/Down/Select/Clear	Pushbutton switches
Sensor ports	RJ-11 (6-4)	8 analog input/power output ports
Beeper	80dB @30cm piezzo	(Optional)
Main relay	0.5A 120VAC 1.0A 24VDC	SPDT (double NO/NC contacts)
Zone relays	0.5A SPST Reed	(Optional, one per port)
Relay contacts access	3mm terminal blocks	
Beeper	80dB @30cm piezzo	
Serial PC interface	4,800 BPS	DB9 female, half duplex
USB PC interface	12,000 BPS	USB 1.0 compatible
PC Ports I/O Protocol	Neodym proprietary	
Power jacks	2.1mm radial	Center negative

**SPECIFICATIONS (CONTINUED)**

**ELECTRICAL**

PARAMETER	SPECIFICATION	NOTES
Input Power Voltage Range	12 VDC +/- 10% 12 to 40 VDC	Standard panel Wide power panels (-HV) only
Power Supply Ripple	250 mV Max.	
Power Consumption	150mA @ 12 VDC	Panel only, not including sensors
Port Power Budget	150mA @ 12 VDC	Per sensor. 1.2A total power max.
Port Power Current Limiting	1.2A @ 12 VDC	10-ohm current limiting resistor
Analog Port Input Voltage	0 to 5 VDC	
Digital Port I/O	One-wire interface	Open collector, bi-directional
Cable type	22-24 SWG	Telephone, Station or Cat. II cable
Cable length	100m max.	Open collector, bi-directional
Electrical Rating	Non-incendiary	Not for use in Hazardous Locations. Approved AC adapters only.

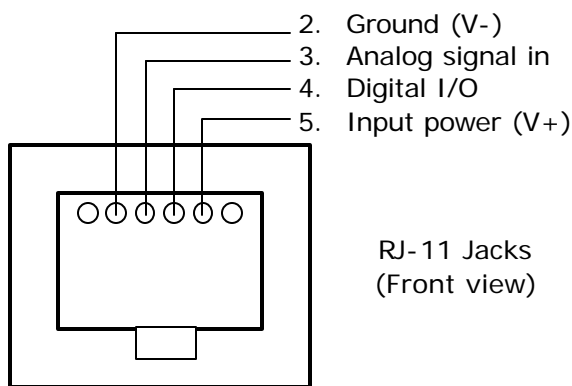

**Related Neodym Documents**

**CONTROL PANEL**

DESCRIPTION	DOCUMENT
Sensor Wiring Diagram	KnowzNet_Wiring.PDF
Control panel relay specifications	Relayszone.PDF

**SENSOR AVAILABLE BY REQUEST**

DESCRIPTION	MODEL	NOTES
Oxygen sensor (electrochemical)	KNET-O2	0 – 25% vol., 0.25% resolution
Ammonia sensor (electrochemical)	KNET-NH3	0-30 PPM, 0.25 PPM resolution
Hydrogen Sulfide (electrochemical)	KNET-H2S	0-100 PPM
Carbon Monoxide (MOS)	KNET-CO	0-200 PPM
Carbon Dioxide	KNET-CO2	0-5,000 PPM
Temperature sensor (semiconductor)	KNET-TC	-40 C to +100 C, 1 C resolution

Please call Neodym for additional sensor head details.